

**HAMMER STRENGTH EQUIPMENT
PLABD PLATE LOADED ABDUCTOR**

REV: C04

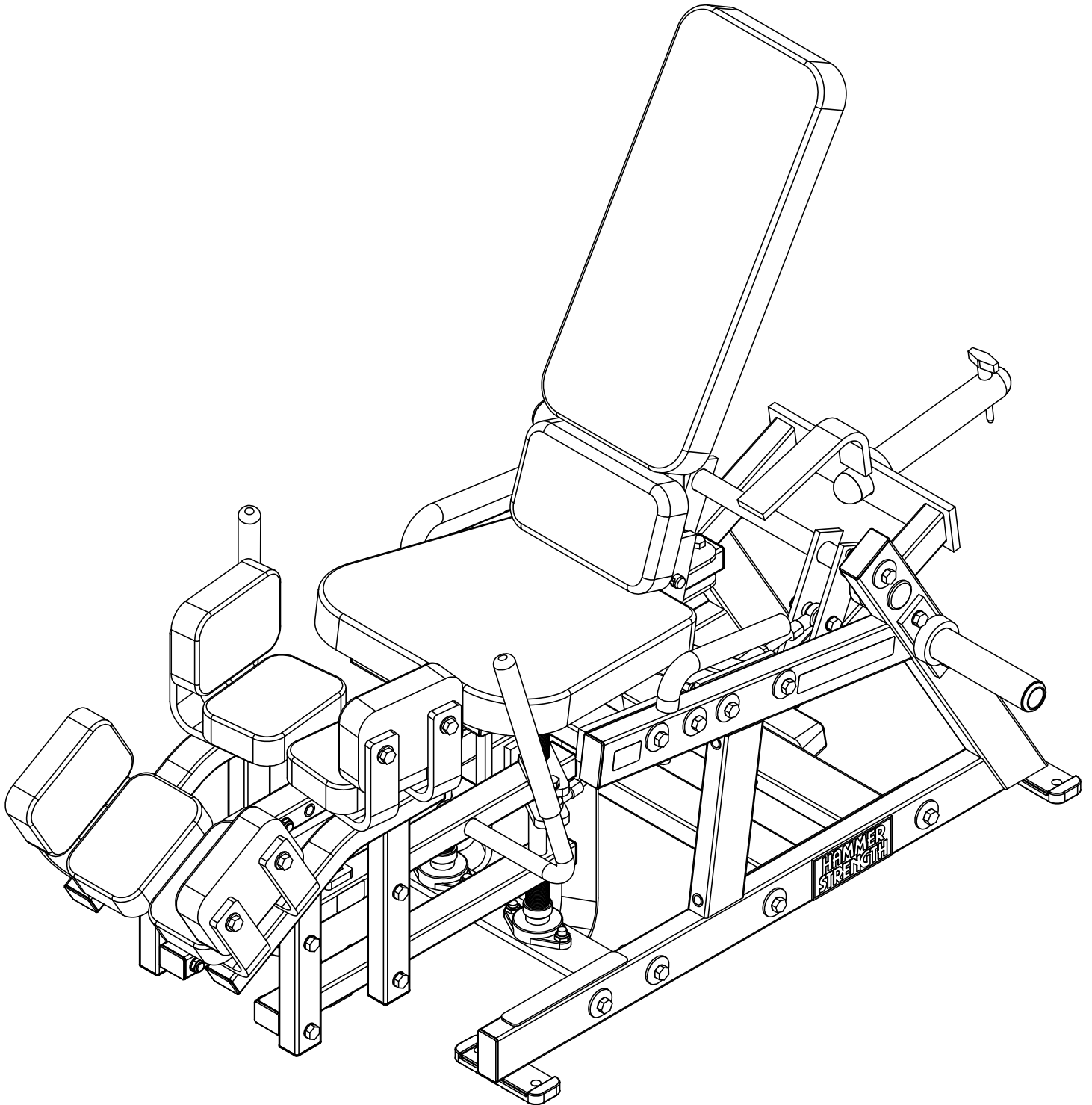

WEIGHT = 270.1 lb
LENGTH = 52"
WIDTH = 57"
HEIGHT = 47"

HAMMER STRENGTH EQUIPMENT EXPLODED VIEW

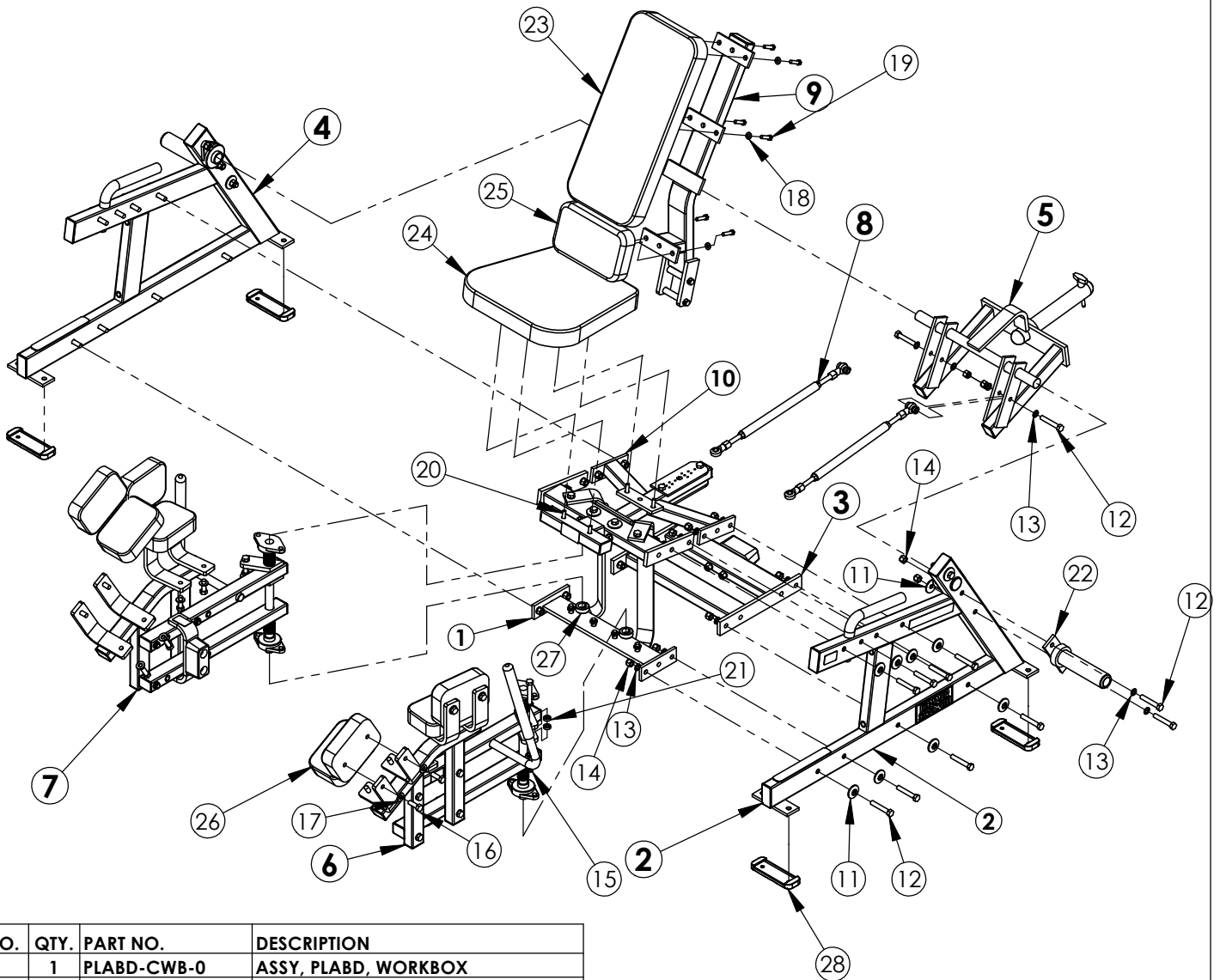

ITEM NO.	QTY.	PART NO.	DESCRIPTION
1	1	PLABD-CWB-0	ASSY, PLABD, WORKBOX
2	1	PLABD-CSFL-1	ASSY, PLABD, LEFT SIDE FRAME
3	1	PLABD-CBX-0	ASSY, PLABD, BOTTOM FRAME
4	1	PLABD-CSFR-1	ASSY, PLABD, RIGHT SIDE FRAME
5	1	PLABD-CHX-2	ASSY, PLABD, WEIGHT ROD
6	1	PLABD-CMAL-1	ASSY, PLABD, LEFT MARM
7	1	PLABD-CMAR-1	ASSY, PLABD, RIGHT MARM
8	2	PLABD-RX-0	ASSY, PLABD, DRIVE ROD
9	1	PLABD-CAJST-0	ASSY, PLABD, SEAT BACK
10	1	PLABD-CST-0	ASSY, PLABD, SEAT MOUNT
11	18	H-BACK-WASH	BACKING WASHER
12	24	HHB.5X3	1/2 X 3 BOLT
13	28	WASH.5STAR	1/2" INTERNAL LOCK WASHER
14	22	NUT.5LOCK	1/2 DIA THICK LOCK NUT
15	2	NUT.5JAMLOCK	1/2 THIN LOCK NUT
16	16	HHB.5X1.5	BOLT, HEX HEAD 1/2 X 1-1/2
17	16	WASH.5SAE	1/2" SAE FLAT WASHER
18	10	WASH.375SAE	3/8" SAE FLAT WASHER
19	8	HHB.375X1.5	STEEL BOLT 3/8 X 1.5
20	2	HHB.375X2.5	STEEL BOLT 3/8 X 2.5
21	8	AB-AD SPACER	AD-AB SPACER
22	2	H-HORN-ASSY	ASSY, WEIGHT HORN
23	1	U-24-10	24X10 PAD
24	1	U-16-11	16X11 PAD
25	1	U-10-4.5S-NC	PAD, 10-4.5
26	8	U-7-4.5	LEG PADS
27	2	H-LCOLLAR1	1" LOCK COLLAR
28	4	MM-8	2 X 6 FLANGE RUBBER SLIPPER

**HAMMER STRENGTH EQUIPMENT
 PLABD-CAJST-0, ASSY, PLABD, SEAT BACK**

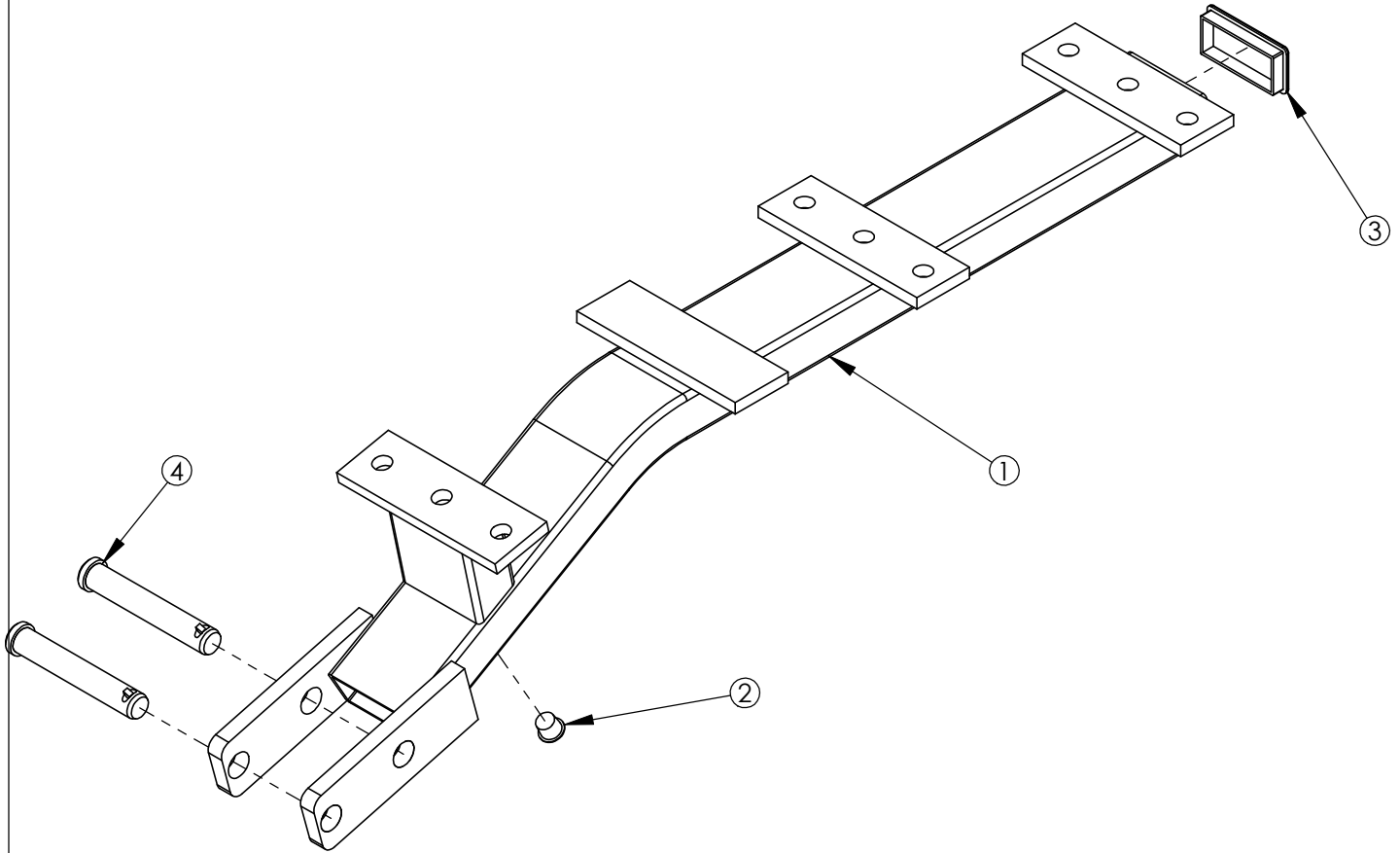

ITEM NO.	QTY.	PART NO.	DESCRIPTION
1	1	PLABD-AJST-0	WLDMT, PLABD, SEAT BACK
2	1	H-HPLUG (REG)	9/16IN HOLE PLUG
3	1	RC1530-1Q1	CAP:1-1/2 X 3 RECTANGLE PLUG
4	2	STD SEAT PIN	LONG SEAT PIN (HDADJ)

WEIGHT = 20 lb
 LENGTH = 34 1/2"
 WIDTH = 6"
 HEIGHT = 8"

**HAMMER STRENGTH EQUIPMENT
 PLABD-CBX-0, ASSY, PLABD, BOTTOM FRAME**

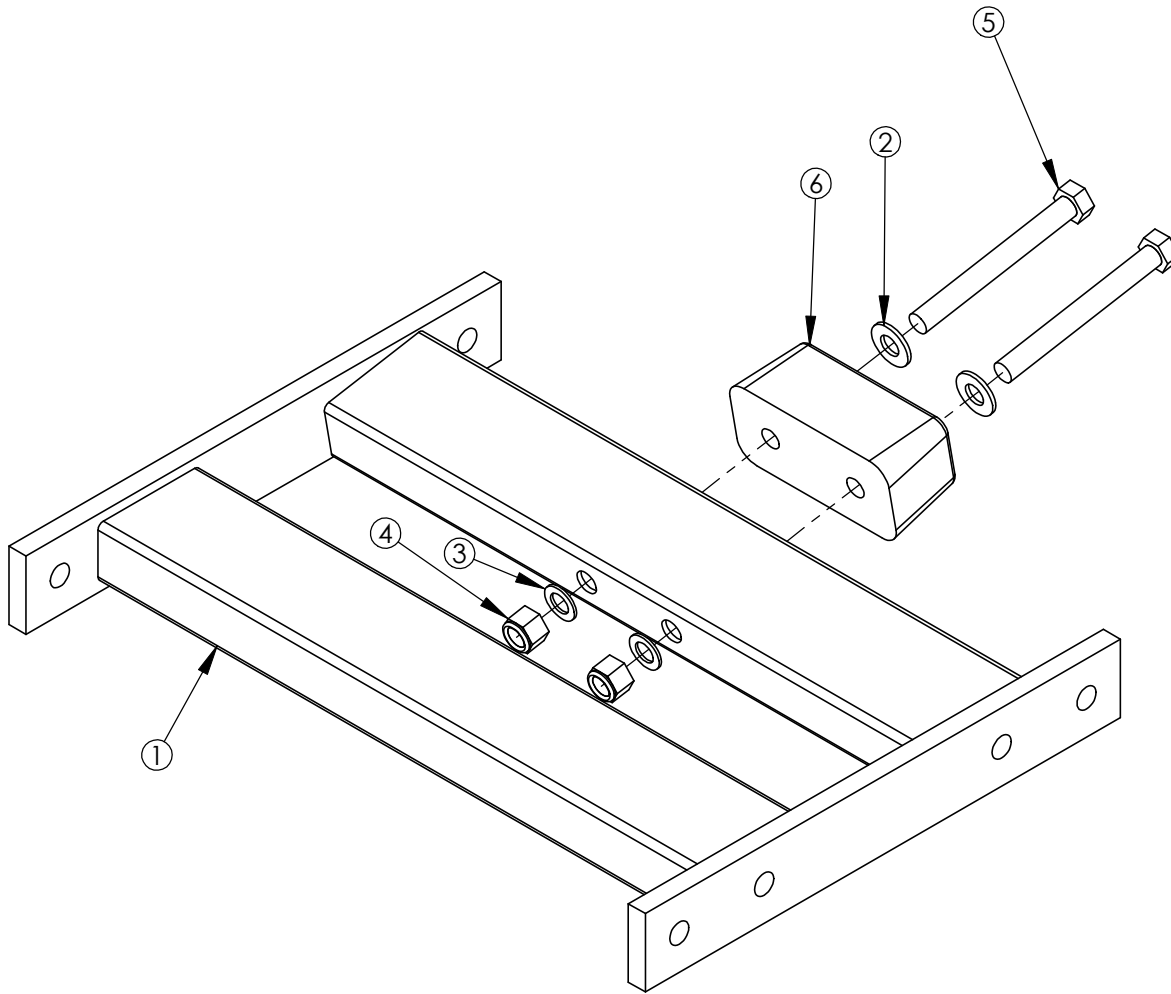

ITEM NO.	QTY.	PART NO.	DESCRIPTION
1	1	PLABD-BX-0	WLDMT, PLABD, BOTTOM X-FRAME
2	2	WASH.5SAE	1/2" SAE FLAT WASHER
3	2	WASH.5STAR	1/2" INTERNAL LOCK WASHER
4	2	NUT.5LOCK	1/2 DIA THICK LOCK NUT
5	2	HHB.5X4.5	1/2 X 4 1/2 BOLT
6	1	H-BUMP-MED	MM2 MEDIUM

WEIGHT = 19 lb
 LENGTH = 14"
 WIDTH = 10 3/4"
 HEIGHT = 4 1/2"

**HAMMER STRENGTH EQUIPMENT
 PLABD-CHX-2, ASSY, PLABD, WEIGHT ROD**

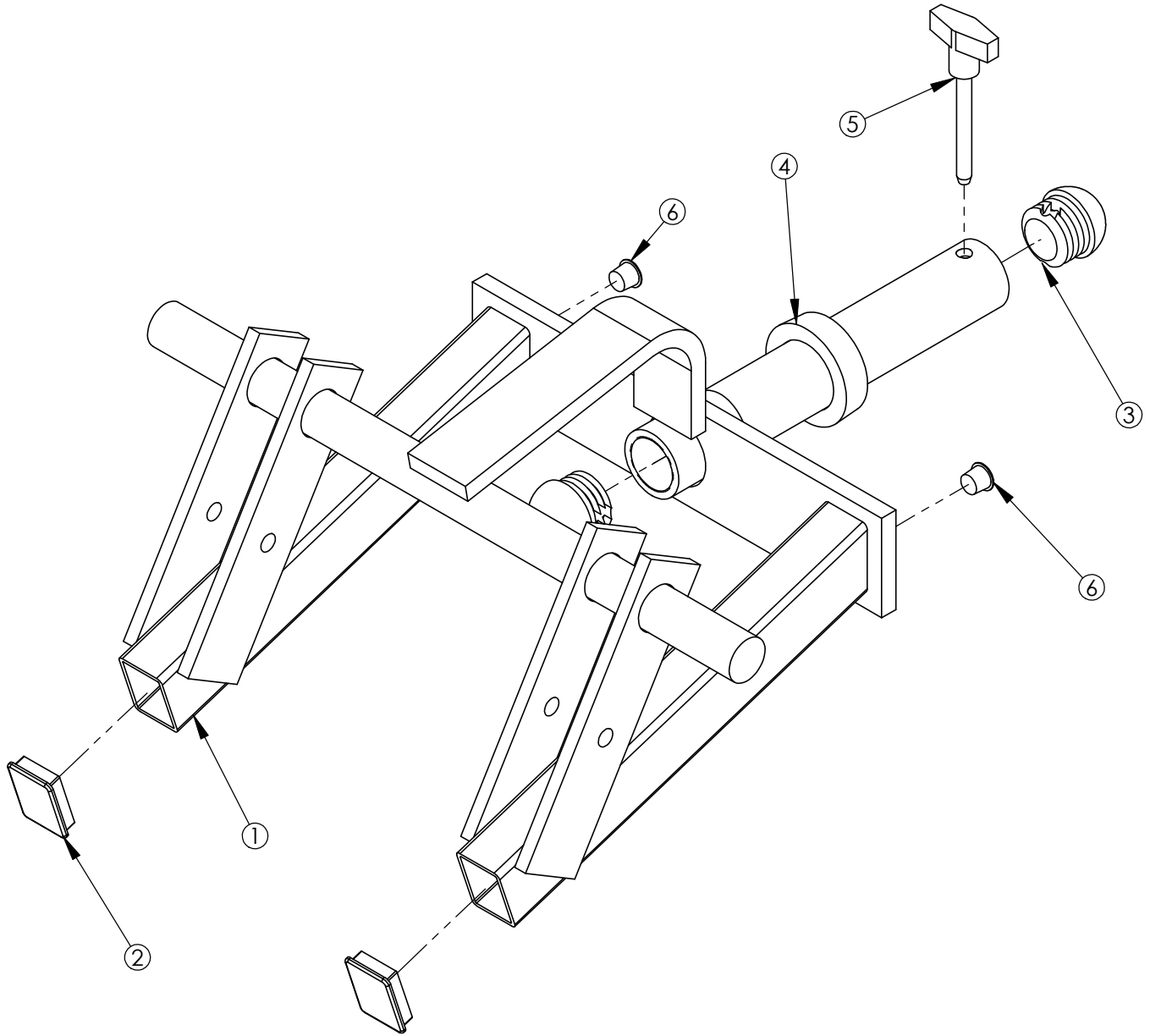

ITEM NO.	QTY.	PART NO.	DESCRIPTION
1	1	PLABD-HX-1	WLDMT, PLABD, WEIGHT ROD
2	2	RC1520-1Q1	CAP:1-1/2 X 2 RECTANGLE PLUG
3	2	RUBCAP1-2	RUBBER CAP #1
4	1	H-RUBRNG	MM5 RING
5	1	SELECTOR PIN-3	SELECTOR PIN 3 IN.
6	2	H-HPLUG (REG)	9/16IN HOLE PLUG

WEIGHT = 32 lb
 LENGTH = 24"
 WIDTH = 20 1/4"
 HEIGHT = 9 1/8"

**HAMMER STRENGTH EQUIPMENT
PLABD-CMAL-1, ASSY, PLABD, LEFT MARM**

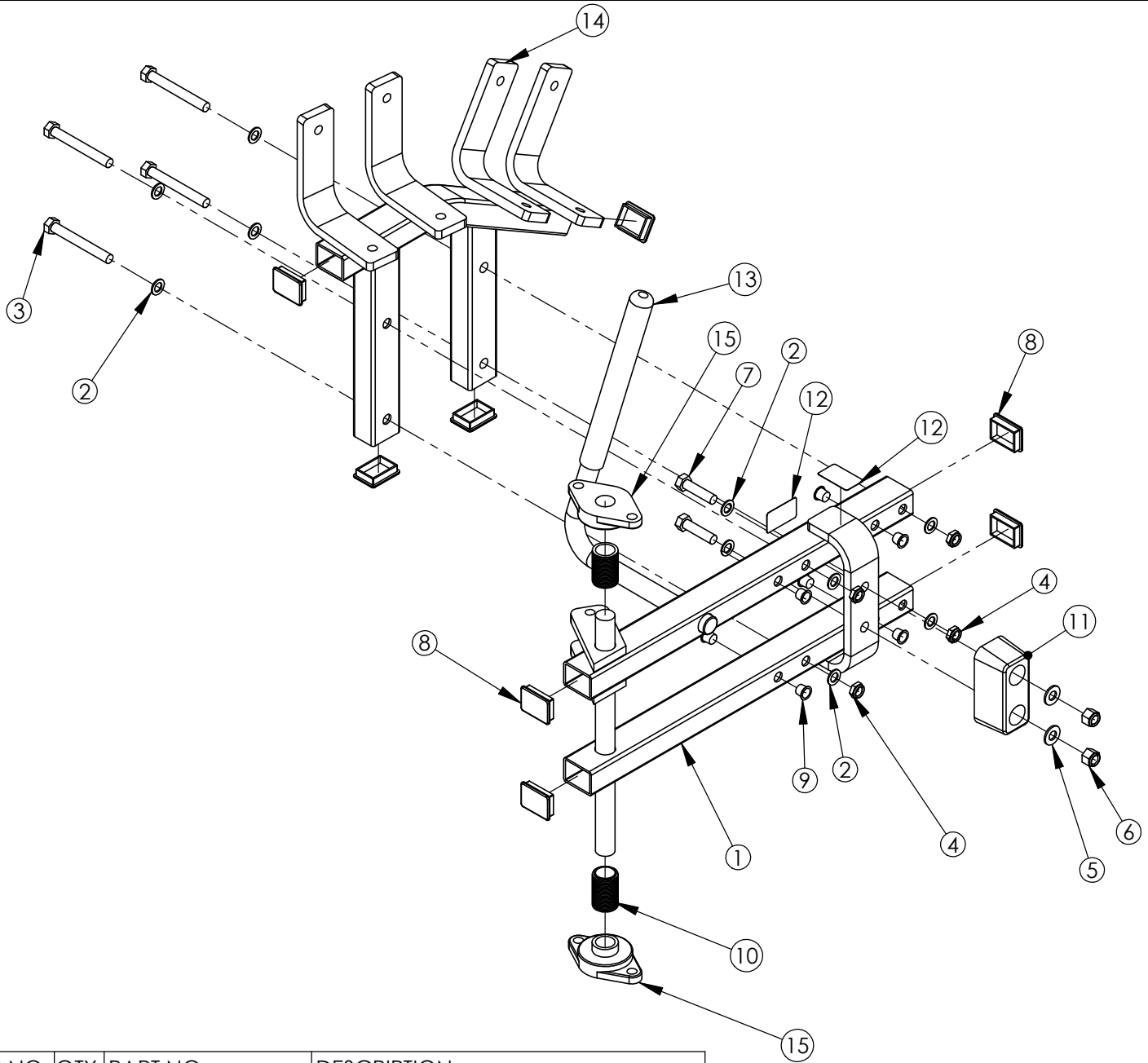

ITEM NO.	QTY.	PART NO.	DESCRIPTION
1	1	PLABD-MAL-1	WLDMT, PLABD LEFT MA
2	10	WASH.5STAR	1/2" INTERNAL LOCK WASHER
3	4	HHB.5X4	1/2 X 4 BOLT
4	4	NUT.5JAMLOCK	1/2 THIN LOCK NUT
5	2	WASH.5SAE	1/2" SAE FLAT WASHER
6	2	NUT.5LOCK	1/2 DIA THICK LOCK NUT
7	2	HHB.5X2	1/2 X 2 BOLT
8	8	RC1520-1Q1	CAP:1-1/2 X 2 RECTANGLE PLUG
9	8	H-HPLUG (REG)	9/16IN HOLE PLUG
10	2	ACCORDIAN	SHAFT GUARD
11	1	H-BUMP-MED	MM2 MEDIUM
12	2	STAY CLEAR	STAY CLEAR DECAL
13	1	H-GRIP	HANDLE GRIPS (.938X16)
14	1	PLABD-ETCL-0	WLDMT, PLABD ETC LEFT
15	2	H-BEAR-SML	SMALL BEARING

WEIGHT = 30.7 lb
 LENGTH = 34 1/8"
 WIDTH = 14"
 HEIGHT = 27 1/4"

HAMMER STRENGTH EQUIPMENT
PLABD-ETCL-0, WLDMT, PLABD ETC LEFT

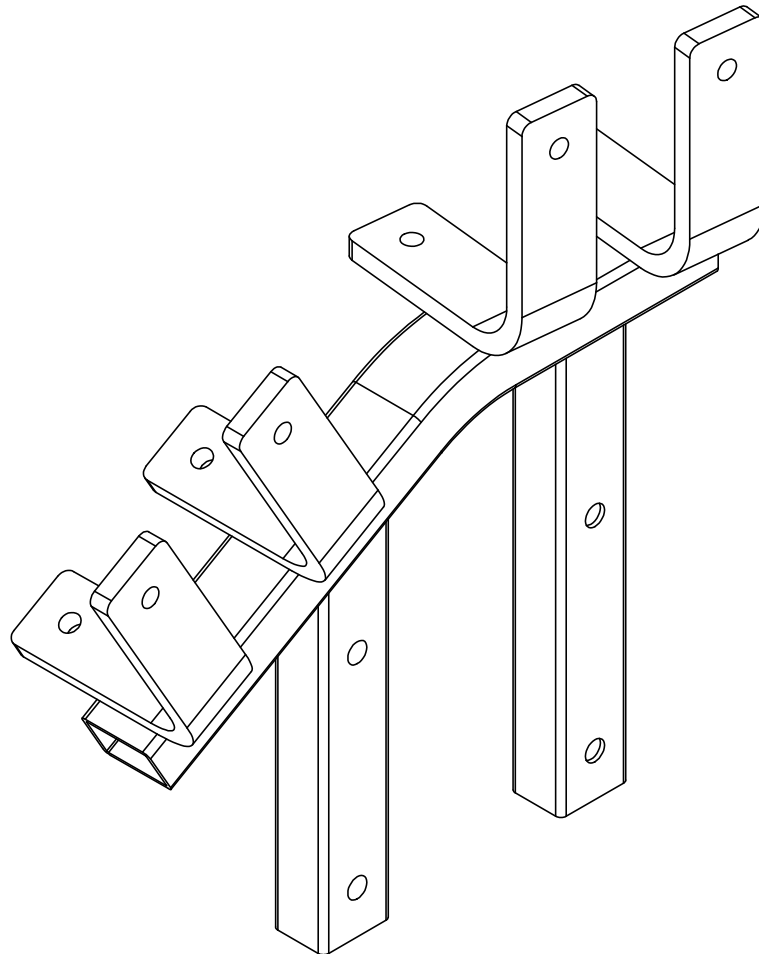

WEIGHT = 22 lb
LENGTH = 19 1/2"
WIDTH = 5 7/8"
HEIGHT = 20"

**HAMMER STRENGTH EQUIPMENT
PLABD-CSFL-1, ASSY, PLABD, LEFT SIDE FRAME**

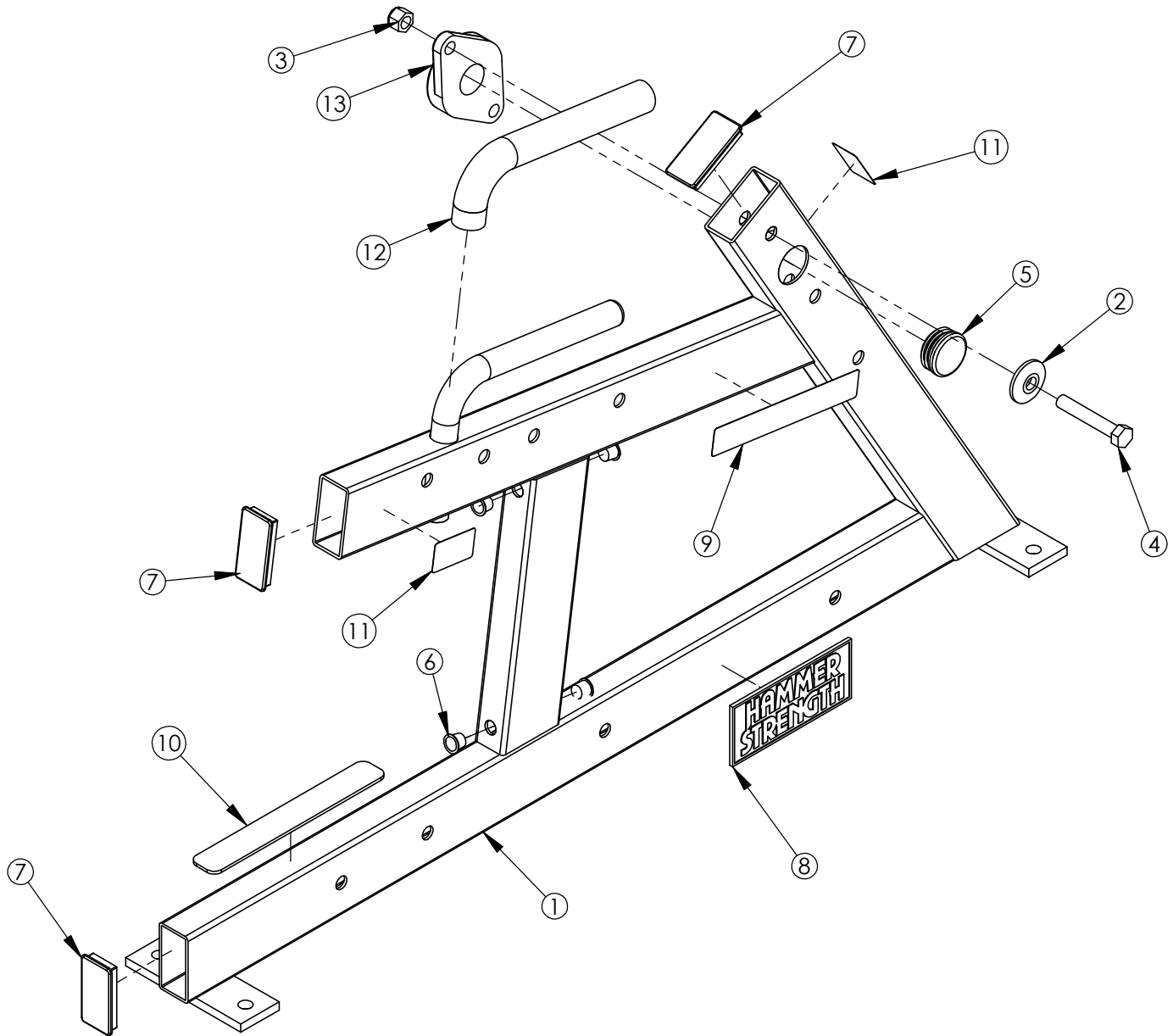

ITEM NO.	QTY.	PART NO.	DESCRIPTION
1	1	PLABD-SF-0	WLDMT, PLABD SF
2	1	H-BACK-WASH	BACKING WASHER
3	1	NUT.5LOCK	1/2 DIA THICK LOCK NUT
4	1	HHB.5X3	1/2 X 3 BOLT
5	1	H-LOCK-PLUG(LARGE)	LARGE LOCKING PLUG
6	4	H-HPLUG (REG)	9/16IN HOLE PLUG
7	3	RC1530-1Q1	CAP:1-1/2 X 3 RECTANGLE PLUG
8	1	H-NAME PLATE	NAMEPLATE (45156-P)
9	1	ADDUCTOR	PRODUCT DECAL
10	1	NONSKID 1 X 9	PLASTIC NON SKID STRIP 1 X 9
11	2	STAY CLEAR	STAY CLEAR DECAL
12	1	H-GRIP	HANDLE GRIPS (.938X16)
13	1	H-BEAR-LGE	LARGE BEAR - EFHSFTJ206-20G

WEIGHT = 35 lb
 LENGTH = 43 7/8"
 WIDTH = 6"
 HEIGHT = 22 1/8"

**HAMMER STRENGTH EQUIPMENT
 PLABD-CST-0, ASSY, PLABD, SEAT MOUNT**

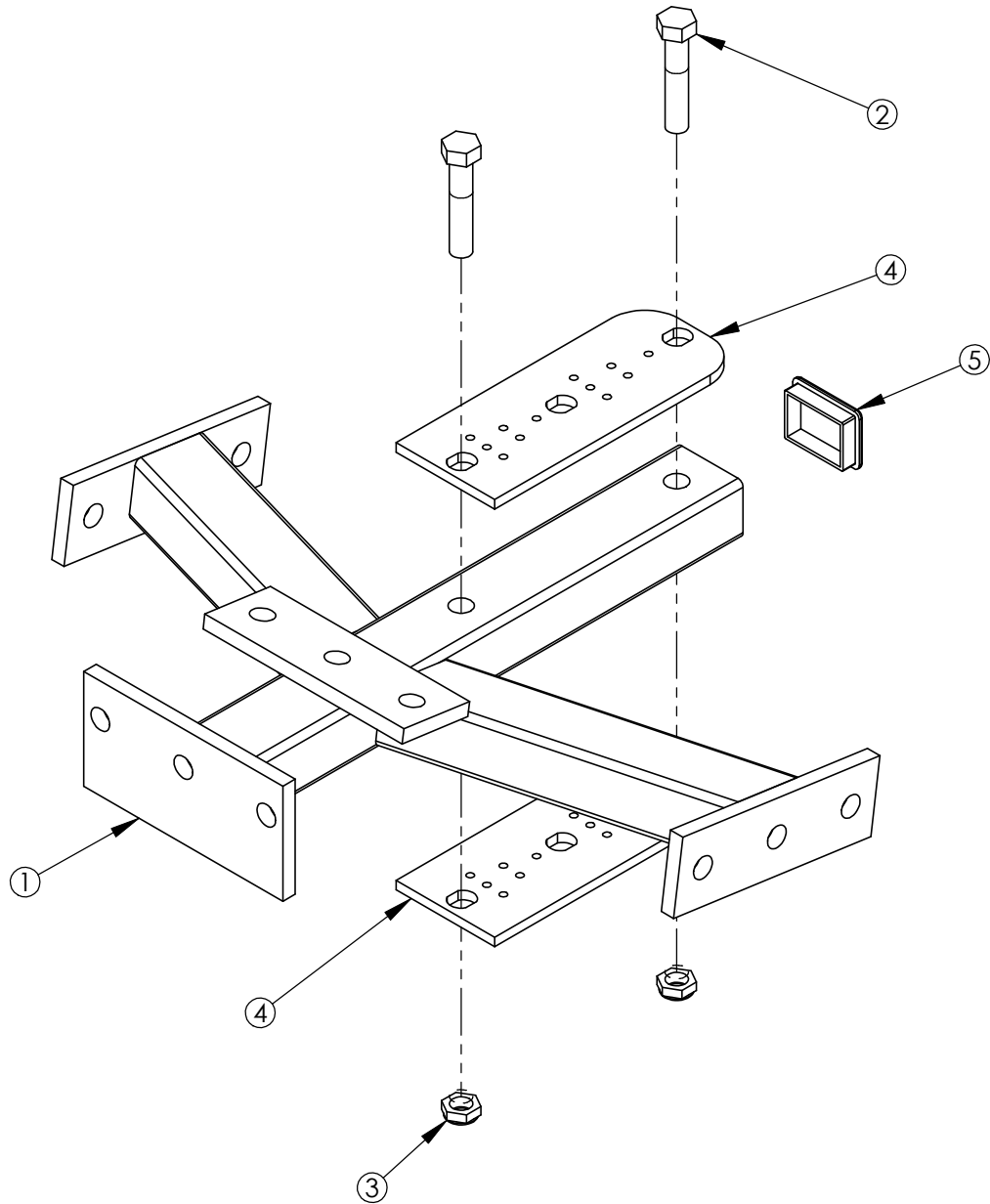

ITEM NO.	QTY.	PART NO.	DESCRIPTION
1	1	PLABD-ST-0	WLDTM, PLABD, SEAT MOUNT
2	2	HHB.5X2.5	1/2 X 2 1/2 BOLT
3	2	NUT.5JAMLOCK	1/2 THIN LOCK NUT
4	2	H-SEATRCKS-SHORT	ORIGINAL SEAT RACK
5	1	RC1520-1Q1	CAP:1-1/2 X 2 RECTANGLE PLUG

WEIGHT = 14 lb
 LENGTH = 16"
 WIDTH = 18 3/4"
 HEIGHT = 3 7/8"

HAMMER STRENGTH EQUIPMENT
PLABD-CWB-0, ASSY, PLABD, WORKBOX

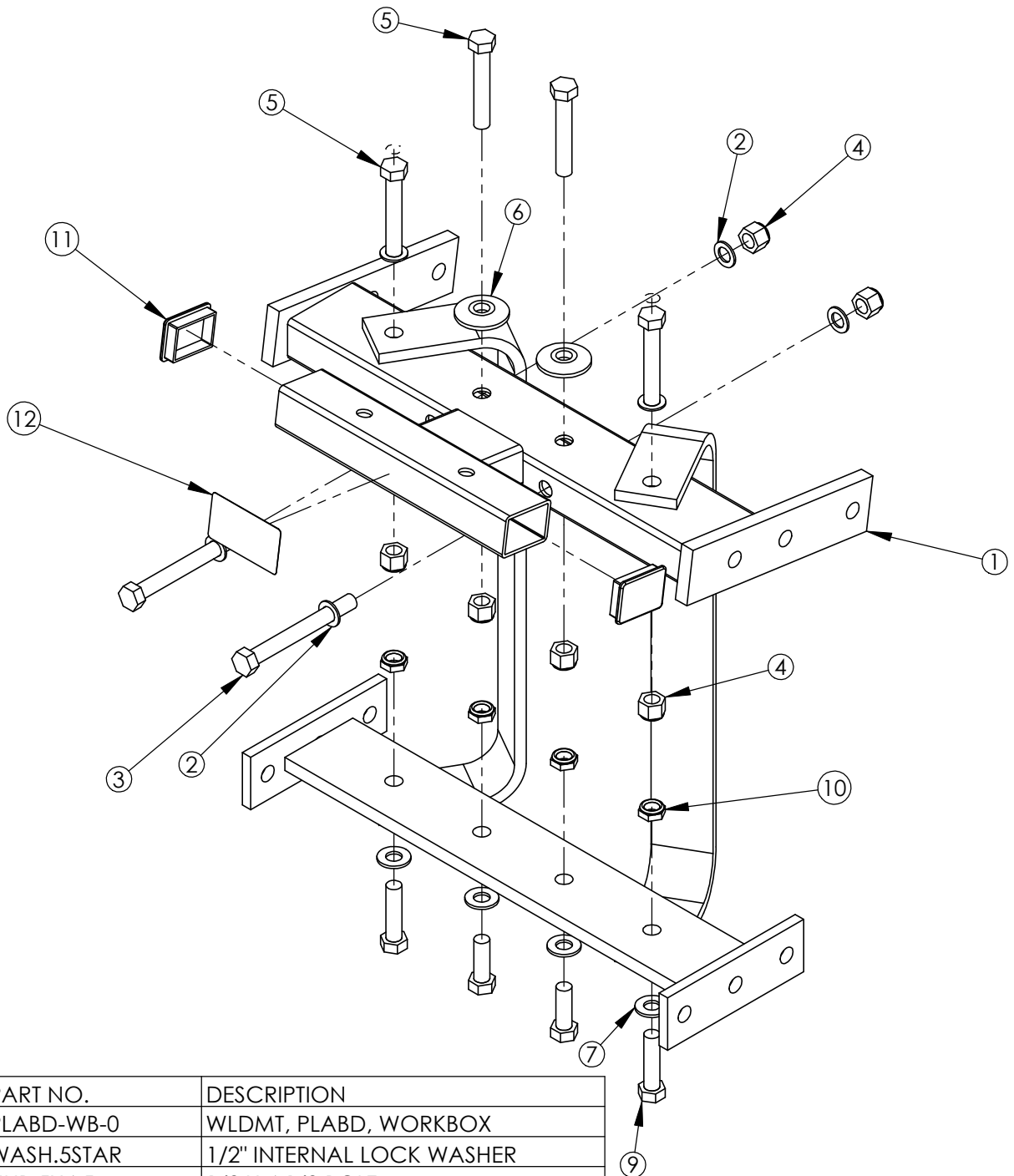

ITEM NO.	QTY.	PART NO.	DESCRIPTION
1	1	PLABD-WB-0	WLDMT, PLABD, WORKBOX
2	6	WASH.5STAR	1/2" INTERNAL LOCK WASHER
3	2	HHB.5X4.5	1/2 X 4 1/2 BOLT
4	6	NUT.5LOCK	1/2 DIA THICK LOCK NUT
5	4	HHB.5X3	1/2 X 3 BOLT
6	2	H-BACK-WASH	BACKING WASHER
7	4	WASH.5SAE	1/2" SAE FLAT WASHER
8	2	HHB.5X1.5	BOLT, HEX HEAD 1/2 X 1-1/2
9	2	HHB.5X2	1/2 X 2 BOLT
10	4	NUT.5JAMLOCK	1/2 THIN LOCK NUT
11	2	RC1520-1Q1	CAP:1-1/2 X 2 RECTANGLE PLUG
12	1	SERIAL NUMBER	SERIAL NUMBER

WEIGHT = 37 lb
 LENGTH = 12"
 WIDTH = 18"
 HEIGHT = 19 5/8"

HAMMER STRENGTH EQUIPMENT
H-HORN-ASSY: WEIGHT HORN ASSEMBLY

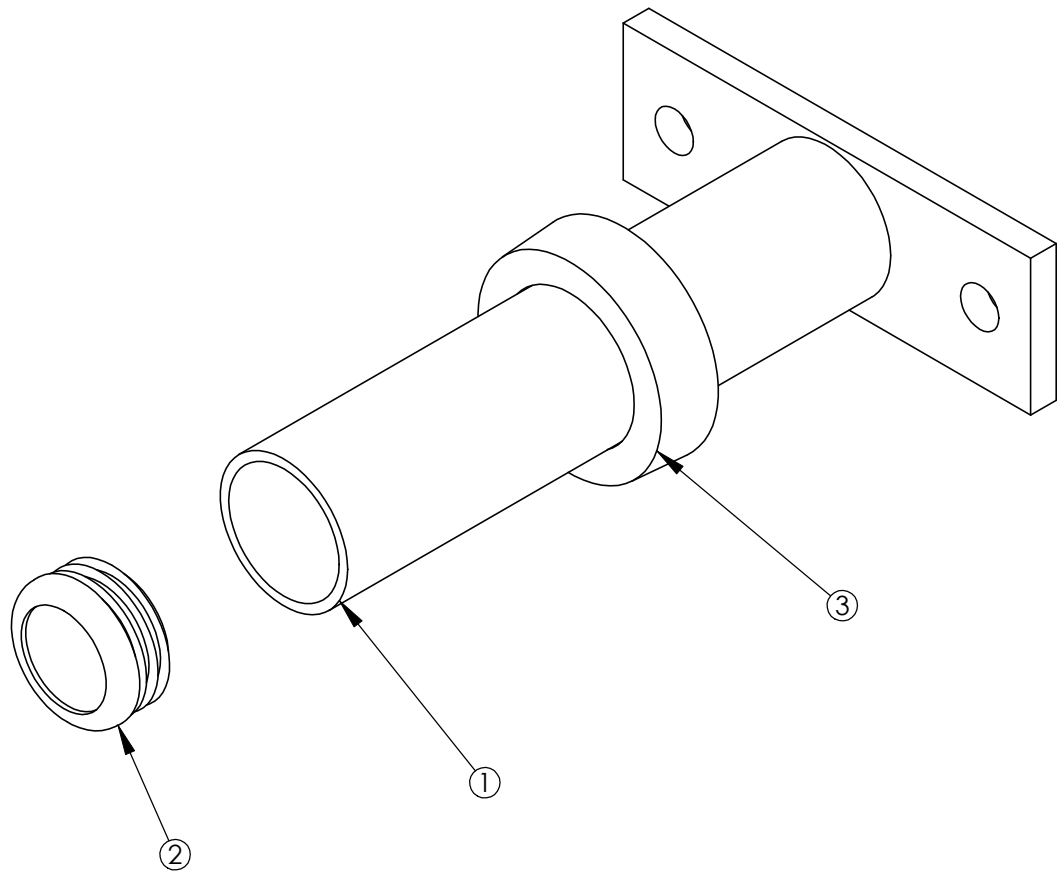

ITEM NO.	QTY.	PART NO.	DESCRIPTION
1	1	H-HORN	WLDMT, WEIGHT HORN
2	1	8078001	CAP, END 1.75 DIA RD 14-20 GA
3	1	H-RUBRNG	MM5 RING

WEIGHT = 3 1/4 lb
 LENGTH = 8 5/8"
 WIDTH = 6"
 HEIGHT = 3"